



CMKZ5221B THRU CMKZ5261B  
**SURFACE MOUNT ULTRAmi™**  
**TRIPLE ISOLATED SILICON**  
**ZENER DIODES**  
**5% TOLERANCE**



# Central™

## Semiconductor Corp.

### DESCRIPTION:

The CENTRAL SEMICONDUCTOR CMKZ5221B Series contains three (3) isolated Silicon Zener Diodes packaged in an ULTRAmi™ SOT-363 surface mount case, designed for use in industrial, commercial, entertainment and computer applications. Higher voltage devices are available on special order.

**MARKING CODE: SEE MARKING CODES ON ELECTRICAL CHARACTERISTICS TABLE**

### MAXIMUM RATINGS: (T<sub>A</sub>=25°C)

Power Dissipation  
 Operating and Storage Junction Temperature  
 Thermal Resistance

### SYMBOL

P <sub>D</sub>	200	mW
T <sub>J</sub> , T <sub>stg</sub>	-65 to +150	°C
θ <sub>JA</sub>	625	°C/W

### ELECTRICAL CHARACTERISTICS PER DIODE: (T<sub>A</sub>=25°C) V<sub>F</sub>=0.9V MAX @ I<sub>F</sub>=10mA (for all types)

Type No.	Zener Voltage V <sub>Z</sub> @ I <sub>ZT</sub>			Test Current I <sub>ZT</sub> (mA)	Maximum Zener Impedance			Maximum Reverse Current		Maximum Temperature Coefficient θ <sub>VZ</sub> (%/°C)	Marking Code
	MIN (V)	NOM (V)	MAX (V)		Z <sub>ZT</sub> @I <sub>ZT</sub> (Ω)	Z <sub>ZK</sub> @ I <sub>ZK</sub> (Ω)	I <sub>R</sub> @ V <sub>R</sub> (μA)	V <sub>R</sub> (V)			
CMKZ5221B	2.280	2.4	2.520	20	30	1200	0.25	100	1.0	-0.085	8A1T
CMKZ5222B	2.375	2.5	2.625	20	30	1250	0.25	100	1.0	-0.085	8B1T
CMKZ5223B	2.565	2.7	2.835	20	30	1300	0.25	75	1.0	-0.080	8C1T
CMKZ5224B	2.660	2.8	2.940	20	30	1400	0.25	75	1.0	-0.080	8D1T
CMKZ5225B	2.850	3.0	3.150	20	29	1600	0.25	50	1.0	-0.075	8E1T
CMKZ5226B	3.135	3.3	3.465	20	28	1600	0.25	25	1.0	-0.070	8ACT
CMKZ5227B	3.420	3.6	3.780	20	24	1700	0.25	15	1.0	-0.065	8BCT
CMKZ5228B	3.705	3.9	4.095	20	23	1900	0.25	10	1.0	-0.060	8CCT
CMKZ5229B	4.085	4.3	4.515	20	22	2000	0.25	5.0	1.0	±0.055	8DCT
CMKZ5230B	4.465	4.7	4.935	20	19	1900	0.25	5.0	2.0	±0.030	8ECT
CMKZ5231B	4.845	5.1	5.335	20	17	1600	0.25	5.0	2.0	±0.030	8FCT
CMKZ5232B	5.320	5.6	5.880	20	11	1600	0.25	5.0	3.0	+0.038	8GCT
CMKZ5233B	5.700	6.0	6.300	20	7.0	1600	0.25	5.0	3.5	+0.038	8HCT
CMKZ5234B	5.890	6.2	6.510	20	7.0	1000	0.25	3.0	4.0	+0.045	8JCT
CMKZ5235B	6.460	6.8	7.140	20	5.0	750	0.25	3.0	5.0	+0.050	8KCT
CMKZ5236B	7.125	7.5	7.875	20	6.0	500	0.25	3.0	6.0	+0.058	8LCT
CMKZ5237B	7.790	8.2	8.610	20	8.0	500	0.25	3.0	6.5	+0.062	8MCT
CMKZ5238B	8.265	8.7	9.135	20	8.0	600	0.25	3.0	6.5	+0.065	8NCT
CMKZ5239B	8.645	9.1	9.555	20	10	600	0.25	3.0	7.0	+0.068	8PCT

ELECTRICAL CHARACTERISTICS PER DIODE - Continued: (T<sub>A</sub>=25°C)  
 V<sub>F</sub>=0.9V MAX @ I<sub>F</sub>=10mA (for all types)

Type No.	Zener Voltage V <sub>Z</sub> @ I <sub>ZT</sub>			Test Current I <sub>ZT</sub> (mA)	Maximum Zener Impedance			Maximum Reverse Current		Maximum Temperature Coefficient ∅V <sub>Z</sub> (%/°C)	Marking Code
	MIN (V)	NOM (V)	MAX (V)		Z <sub>ZT</sub> @I <sub>ZT</sub> (Ω)	Z <sub>ZK</sub> @ I <sub>ZK</sub> (Ω)	I <sub>R</sub> @ V <sub>R</sub> (μA)	V <sub>R</sub> (V)			
CMKZ5240B	9.500	10	10.50	20	17	600	0.25	3.0	8.0	+0.075	8QCT
CMKZ5241B	10.45	11	11.55	20	22	600	0.25	2.0	8.4	+0.076	8RCT
CMKZ5242B	11.40	12	12.60	20	30	600	0.25	1.0	9.1	+0.077	8SCT
CMKZ5243B	12.35	13	13.65	9.5	13	600	0.25	0.5	9.9	+0.079	8TCT
CMKZ5244B	13.30	14	14.70	9.0	15	600	0.25	0.1	10	+0.082	8UCT
CMKZ5245B	14.25	15	15.75	8.5	16	600	0.25	0.1	11	+0.082	8VCT
CMKZ5246B	15.20	16	16.80	7.8	17	600	0.25	0.1	12	+0.083	8WCT
CMKZ5247B	16.15	17	17.85	7.4	19	600	0.25	0.1	13	+0.084	8XCT
CMKZ5248B	17.10	18	18.90	7.0	21	600	0.25	0.1	14	+0.085	8YCT
CMKZ5249B	18.05	19	19.95	6.6	23	600	0.25	0.1	14	+0.086	8ZCT
CMKZ5250B	19.00	20	21.00	6.2	25	600	0.25	0.1	15	+0.086	1A8T
CMKZ5251B	20.90	22	23.10	5.6	29	600	0.25	0.1	17	+0.087	1B8T
CMkZ5252B	22.80	24	25.20	5.2	33	600	0.25	0.1	18	+0.088	1C8T
CMKZ5253B	23.75	25	26.25	5.0	35	600	0.25	0.1	19	+0.089	1D8T
CMKZ5254B	25.65	27	28.35	4.6	41	600	0.25	0.1	21	+0.090	1E8T
CMKZ5255B	26.60	28	29.40	4.5	44	600	0.25	0.1	21	+0.091	1F8T
CMKZ5256B	28.50	30	31.60	4.2	49	600	0.25	0.1	23	+0.091	1G8T
CMKZ5257B	31.35	33	34.65	3.8	58	700	0.25	0.1	25	+0.092	1H8T
CMKZ5258B	34.20	36	37.80	3.4	70	700	0.25	0.1	27	+0.093	1J8T
CMKZ5259B	37.05	39	40.95	3.2	80	800	0.25	0.1	30	+0.094	1K8T
CMKZ5260B	40.85	43	45.15	3.0	93	900	0.25	0.1	33	+0.095	1L8T
CMKZ5261B	44.65	47	49.35	2.7	105	1000	0.25	0.1	36	+0.095	1M8T

SOT-363 CASE - MECHANICAL OUTLINE

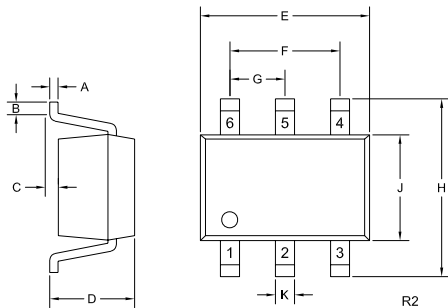

SYMBOL	DIMENSIONS		DIMENSIONS	
	INCHES		MILLIMETERS	
	MIN	MAX	MIN	MAX
A	0.004	0.010	0.10	0.25
B	0.005	-	0.12	-
C	0.000	0.004	0.00	0.10
D	0.031	0.043	0.80	1.10
E	0.071	0.087	1.80	2.20
F	0.051	-	1.30	-
G	0.026	-	0.65	-
H	0.075	0.091	1.90	2.30
J	0.043	0.055	1.10	1.40
K	0.006	0.012	0.15	0.30

SOT-363 (REV: R2)

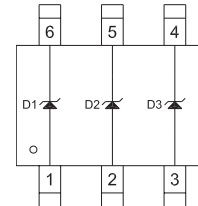

LEAD CODE:  
 1) ANODE D1  
 2) ANODE D2  
 3) ANODE D3  
 4) CATHODE D3  
 5) CATHODE D2  
 6) CATHODE D1

R1 (21-November 2008)